

Portable Electric Drill

I. Competencies

Given a properly adjusted portable electric drill, accessories, instruction and demonstration of use, each student will be able to:

- A. Identify the major parts of the portable electric drill.
- B. Pass a written test on safety and operating procedures of the portable electric drill with 100 percent accuracy.
- C. Demonstrate ability to use the portable electric drill, following suggested safety rules and correct operation procedures.

II. Instructional Materials and Procedures

A. Identification of basic portable electric drill parts.

- | | |
|-------------------------|---------------------|
| 1. Pistol Grip | 5. Trigger Switch |
| 2. Cord Strain Reliever | 6. Chuck Wrench |
| 3. Electrical Cord | 7. Reversing Switch |
| 4. Switch Lock | 8. Chuck |

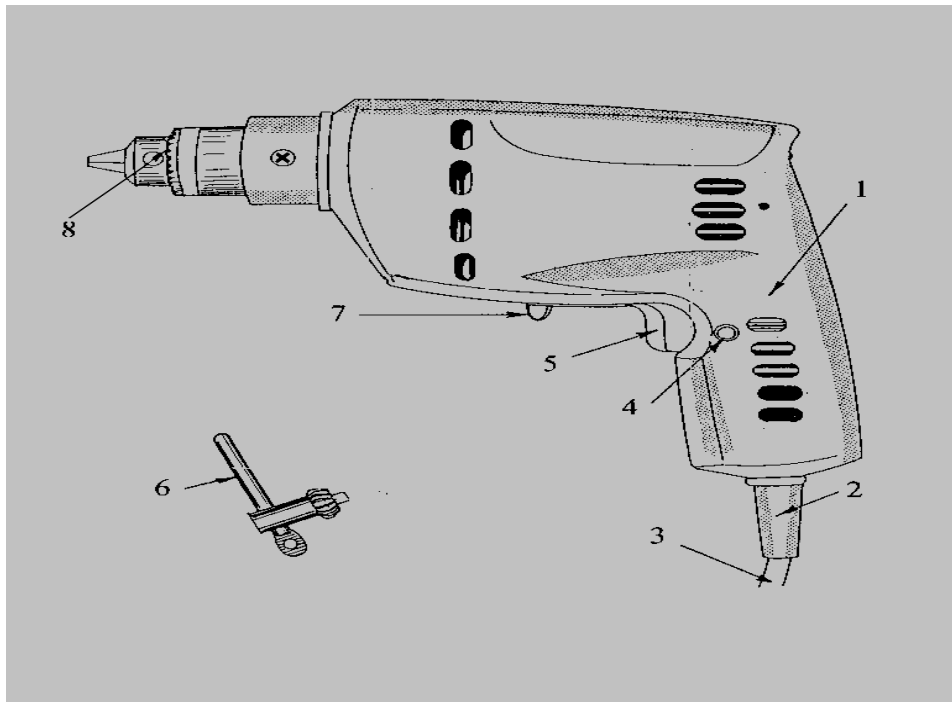

B. Portable Electric Drill Safety

1. Wear safety glasses when operating with portable electric drill.
2. Disconnect the drill from the electrical supply when installing bits.
3. Clamp stock so it will not move during the drilling operation.
4. Before drilling, turn the drill on to see if the bit is centered and running true.
5. Align the bit with the desired hole location before turning the drill on.
6. Hold the drill firmly with both hands while drilling.
7. When drilling deep holes with a twist drill, move the bit up and down several times while drilling to remove cuttings and reduce overheating in the bit.
8. Do not allow the cord to become wrapped around the drill when working.
9. If the electrical cord becomes frayed or starts to separate from the drill housing, repair it immediately!
10. Remove the bit from the drill as soon as the work is completed.
11. Select the correct bit for the finish and material being drilled. Make sure the bit is securely tightened in the drill chuck.
12. Be extremely careful when using larger portable electric drills (3/8" and 1/2"). If the bit should hang or get caught the drill will twist in the operators hands causing a sprain or bruised fingers.
13. Always remove the key from the chuck before drilling.
14. To prevent seizing, reduce the feed pressure when the drill bit is about to come through the material.

C. Operating Procedures

1. Always center punch or make a starting indentation in the material being drilled to get an accurate starting point for the drill bit.
2. Tighten the drill bit by rotating the chuck key to all three holes in the chuck. This will help to keep the drill bit centered.

3. Use only straight shank or Silver and Deming drill bits in portable electric drills.
4. Apply moderate even pressure to the drill during the drilling operation. If excessive pressure is required to make the bit cut then the bit is dull and needs to be sharpened.
5. Maintain good balance at all times when drilling.
6. Use slow drill speeds for drilling metal and fast speeds for drilling wood.
7. To obtain holes that are placed accurately, drill a small pilot first then drill the final hole.

III. Written Test

Portable Electric Drill Safety and Operation Test

Name _____ Date _____ Class _____

Multiple Choice - Place the letter of the most correct answer on the answer sheet.

1. The purpose of turning the drill on before attempting to drill a hole is to _____.
 - a. see if the drill operates.
 - b. see if the drill bit is running true.
 - c. make sure the chuck key has been removed.
 - d. none of these.

2. The purpose of moving the drill and bit up and down often when drilling deep hole is to _____.
 - a. ream the hole slightly larger.
 - b. give the drill operator better drilling leverage.
 - c. help keep the hole centered.
 - d. reduce overheating in the drill bit.

3. If a large capacity portable drill bit hangs during the drilling operation what will likely happen?
 - a. The bit will break.
 - b. The drill will twist in the operator's hands causing a sprained wrist or bruised fingers.
 - c. The drill will likely stall out and overheat.
 - d. The hole will become badly distorted.

4. What kind of pressure should be applied to a drill during the drilling operation?
 - a. Light, even.
 - b. Medium, even.
 - c. Moderate, even.
 - d. Heavy, even.

5. What type of drill speed is needed for wood drilling operations?
 - a. Low
 - b. Low-medium
 - c. Medium
 - d. High

6. What type of drill speed is needed for most metal drilling operations?
 - a. Low
 - b. Medium-low
 - c. Medium-high
 - d. High

7. The purpose of a pilot hole when drilling is to _____.
 - a. make the final hole drilling operation easier.
 - b. guide the final drilling operation and achieve a more accurately place hole.
 - c. reduce the feed pressure needed to drill the hole.
 - d. allow the final hole to be drilled at a faster rpm and achieve a smoother finish.

8. To prevent seizing when drilling the operator should _____.
 - a. reduce the rpm's of the portable electric drill
 - b. lubricate the drill bit.
 - c. use a high speed drill bit.
 - d. reduce the feed pressure when the bit is about to come through the material being drilled.

IV. Performance Test for the Portable Electric Drill

Name _____ Date _____ Class _____

The student performs the following while operating the portable electric drill.

	Yes	No	N/A
1. Safety glasses are worn while the portable electric drill is being used.	_____	_____	_____
2. The portable drill is unplugged while the drill bit is being changed.	_____	_____	_____
3. The drill bit is tight in the chuck, runs true, and the chuck wrench has been removed from the chuck key before the drilling operation begins .	_____	_____	_____
4. The portable electric drill is held firmly in both hands as the switch is turned on and as the hole is being drilled.	_____	_____	_____
5. The portable electric drill has stopped rotating before the drill is laid down.	_____	_____	_____
6. The portable electric drill is positioned so that chips are thrown away from the operator and others working in the area.	_____	_____	_____
7. The electrical cord and extension cord(s) are positioned away from the work being performed.	_____	_____	_____
8. The student can properly select, remove and replace bits on the portable electric drill.	_____	_____	_____
9. The correct drill speed is selected for the type of material being drill.	_____	_____	_____
10. The student can safely control the portable electric drill and perform satisfactory drill work.	_____	_____	_____

Comments _____

I do hereby certify that the student has satisfactorily demonstrated ability to operate the portable electric drill by passing this performance test.

 Student Date Teacher Date

Portable Electric Drill Parts Identification Test

Name _____

Match the number of each portable electric drill part to the correct part name.

- ___ A. Chuck
- ___ B. Chuck Wrench
- ___ C. Cord Strain Reliever
- ___ D. Electrical Cord
- ___ E. Pistol Grip
- ___ F. Reversing Switch
- ___ G. Switch Lock
- ___ H. Trigger Switch

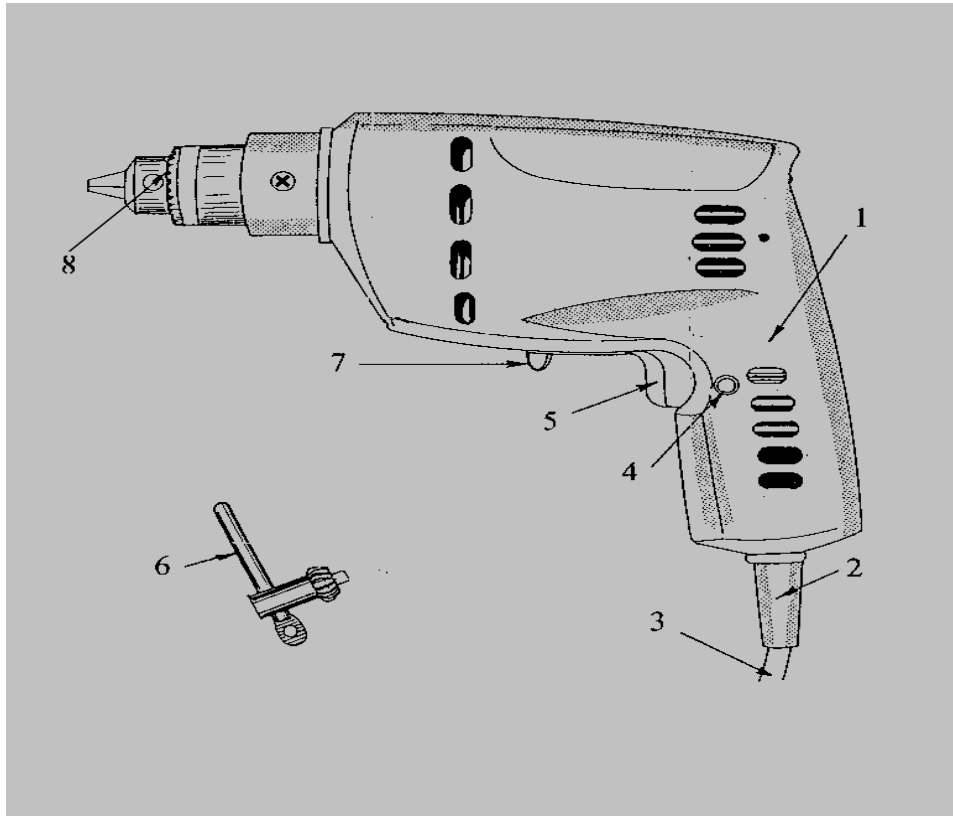

Portable Electric Drill

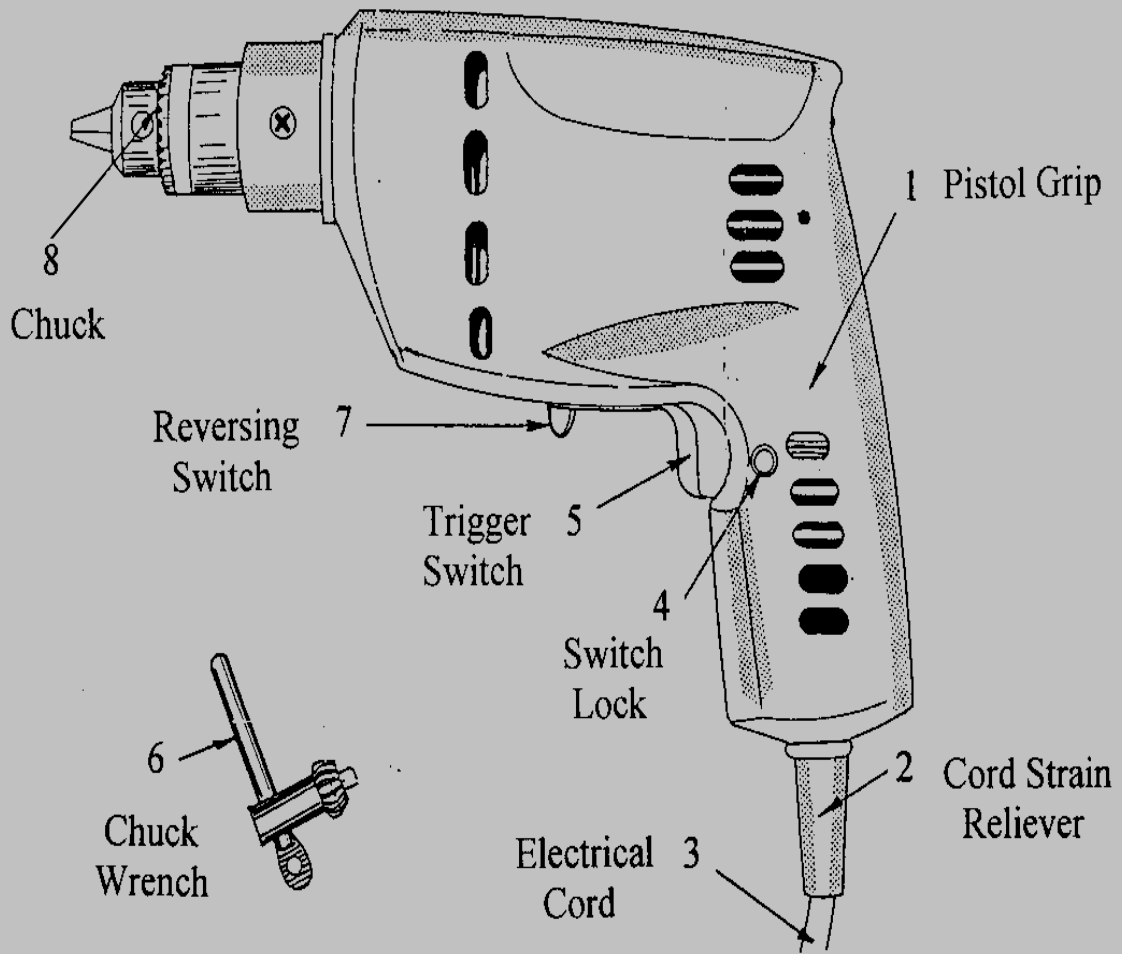

Portable Electric Drill

