

Portable Grinder

I. Competencies

Given a properly adjusted portable grinder, instruction and demonstration of use, each student will be able to:

- A. Identify the major parts of the portable grinder.
- B. Complete a written test on safety and operating procedures of the portable grinder with 100 percent accuracy.
- C. Demonstrate the ability to use the portable grinder while following all safety rules and correct operating procedures.

II. Instructional Materials and Procedures

A. Identification of basic portable grinder parts:

- | | |
|-------------------|-------------------------|
| 1. Fore-handle | 5. Rear handle |
| 2. Wheel guard | 6. Cord strain reliever |
| 3. Grinding wheel | 7. Trigger switch |
| 4. Tool rest | 8. Switch lock |

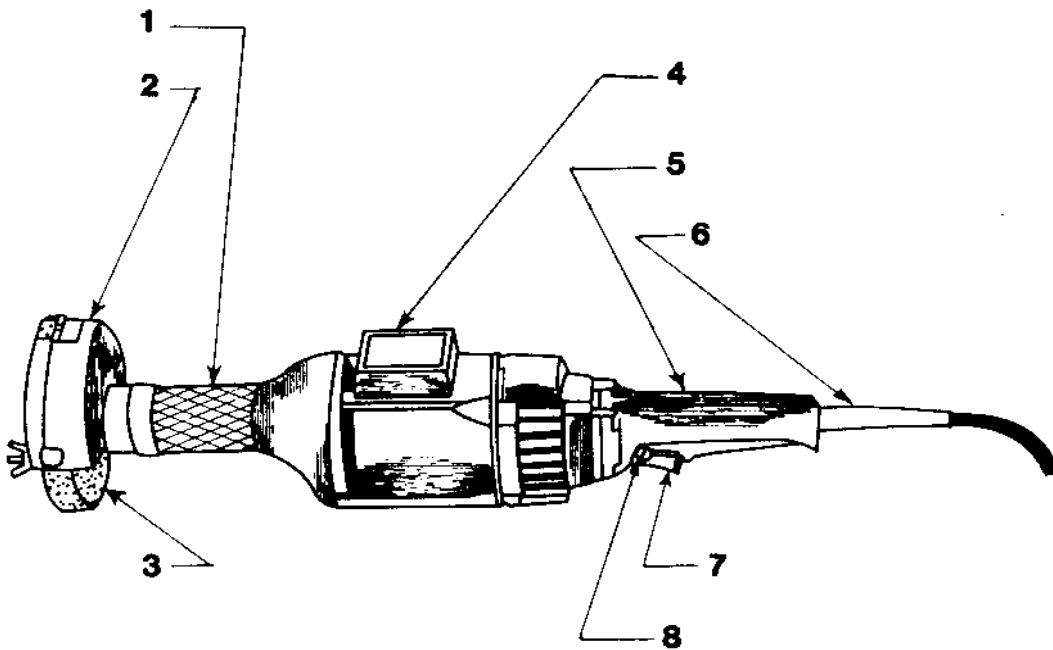

B. Portable Grinder Safety

1. Obtain the instructor's permission before operating the portable grinder.
2. Wear an industrial quality eye protection, i.e., a face shield and safety glasses. Ear protectors are recommended. Be sure the grinder is properly grounded or double insulated.
3. Be sure the switch is off and the cord disconnected from the power source before adjusting, lubricating, inspecting or changing grinding wheels.
4. Never use a cracked grinding wheel or one that vibrates excessively.
5. Use only wheels that are designed to operate at the speed indicated on the grinder nameplate. The exposed area of the grinding wheel should not exceed more than $\frac{1}{4}$ of the area of the entire wheel.
6. The wheel guard should be in place and used at all times when operating the portable grinder.
7. Do not direct the grinder discharge sparks at yourself or others. The sparks may cause burns, fires and/or small pieces of metal or grit to become in the skin.
8. When grinding small pieces, be sure they are held securely in a vise clamped to a table.
9. Do not talk to anyone while operating the grinder.
10. Never use the grinder in areas where flammable materials are stored.
11. Remove or fasten loose articles of clothing such as long sleeve, coats, neck ties, and confine long hair when using the grinder.
12. Make sure the floor around your work area is clean before operating the grinder.
13. Keep the power cord away from the grinding wheel and material being ground.
14. Hold the grinder firmly with both hands.
15. After use always make sure the switch is turned off before the grinder is put down.
16. Never operate the portable grinder while standing in water or on a wet floor.
17. Never use a grinding wheel which is worn to less than $\frac{1}{2}$ of its original diameter.
18. Make certain the grinding wheel is fastened securely to the arbor. Perform this check with the power disconnected.
19. Never lay down a grinder while the wheel is turning.
20. Do not force the grinder into the metal.

C. Portable Grinder Operating Procedure

1. Wear an industrial quality face shield and safety glasses when grinding.

2. Select a grinding wheel which will fit the arbor shaft.
3. Match the R.P.M. range of the wheel to the R.P.M. of the grinder when selecting grinder wheels. This protects the wheel from exploding due to high R.P.M. and rim speed.
4. Sound the grinding wheel for cracks before installing.
5. Be sure the grinding wheel is kept at room temperature. A very cold wheel may become frozen and break when used.
6. Firmly secure all work to the ground.
7. Hold the grinder with both hands when using.
8. Be sure the wheel guard is in place when grinding.
9. Be sure that no one is in line with the grinding wheel when you start the grinder.
10. Turn the grinder on and off to see if the grinding wheel vibrates excessively and that it runs true.
11. Feed the grinding wheel lightly into the work after the motor has reached full operating speed.
12. Do not force the grinder into the work causing wheel speed to be reduced.
13. Do not lay the grinder down until the wheel has stopped turning.
14. Lay the grinder on its rest so nothing touches the grinding wheel while it is not in use.
15. Return the portable grinder to its proper storage place after use.

III. SAFETY TEST

Portable Grinder Safety and Operation Test

Name _____ Date _____ Class _____

Multiple Choice – Place the letter off the most correct answer on the answer sheet.

1. When using the portable grinder which of the following should NOT be done:
 - a. Use the wheel guard at all times
 - b. Hold the grinder with both hands
 - c. Force the grinder into the metal
 - d. Direct the sparks away from you

2. When setting up the portable grinder and before grinding takes place, always _____.
 - a. sound the grinding wheel for cracks
 - b. make sure the grinding wheel fits the arbor shift
 - c. turn the grinder motor on and off to see if the wheel vibrates excessively or does not run true
 - d. all of the above

3. The operator of a portable power grinder should wear _____.
 - a. safety glasses
 - b. a face shield
 - c. ear protection
 - d. all of the above

4. Before using the portable grinder the operator should _____.
 - a. lock the trigger switch
 - b. remove the wheel guard
 - c. put the electrical cord on the work to be ground
 - d. none of the above

5. Do NOT use a grinding wheel which is _____.
 - a. rated at a lower r.p.m. than that of the grinder
 - b. a resinoid bond
 - c. rated at a higher r.p.m. than that of the grinder
 - d. a vitrified bond

6. The maximum surface area of a grinding wheel that can be exposed by the wheel guard is _____.
- $1/8$
 - $1/4$
 - $3/8$
 - $1/2$
7. The wheel guard should be used on the grinder _____.
- at all times
 - when grinding ferrous metal
 - when grinding in a confined area
 - when the wheel has worn less than $1/2$ of its original diameter
8. Sparks from the grinder should be directed _____.
- down toward the ground
 - away from yourself and others
 - up in the air
 - toward an exhaust vent
9. Never use grinding wheel which is less than _____ of the original diameter?
- $3/4$
 - $5/8$
 - $1/2$
 - $3/8$
10. When finished using a portable grinder make sure _____.
- the grinding wheel has stopped rotating before putting the grinder down
 - the grinder is placed down on the tool rest
 - the grinder is returned to its proper storage place
 - all of the above

IV. Performance Test for Portable Grinder

The student performs the following while using the portable grinder.

	Yes	No	N/A
1. Industrial quality safety glasses, face shields, and ear protectors are worn.	___	___	___
2. Loose clothing and jewelry are not worn by the operator.	___	___	___
3. The floor and work area are kept clean.	___	___	___
4. The grinding wheel is checked for cracks.	___	___	___
5. The grinder motor is turned on and off quickly to check for excessive vibration and out-of-round grinding wheel.	___	___	___
6. The wheel guard is kept in place and properly adjusted.	___	___	___
7. The metal being ground is properly secured.	___	___	___
8. The grinder is allowed to reach full speed before being applied to the work.	___	___	___
9. Discharge sparks from the grinder are directed into suitable locations.	___	___	___
10. The grinding wheel has stopped turning before the grinder is put down.	___	___	___
11. The grinder is place on the tool rest when it is not in use.	___	___	___
12. Both hands are kept on the grinder while it is being used.	___	___	___
13. Work procedures are safe and acceptable.	___	___	___
14. Correct procedures are used in grinding.	___	___	___

Comments _____

Signed (Student)

Date

Signed (Teacher)

Date

Portable Grinder Parts Identification Test

Name _____

Match the number of each portable grinder part with the letter of the correct part name.

- | | |
|--------------------|-----------------------------|
| ___ A. Tool rest | ___ E. Wheel guard |
| ___ B. Fore handle | ___ F. Grinding wheel |
| ___ C. Switch lock | ___ G. Trigger switch |
| ___ D. Rear handle | ___ H. Cord strain reliever |

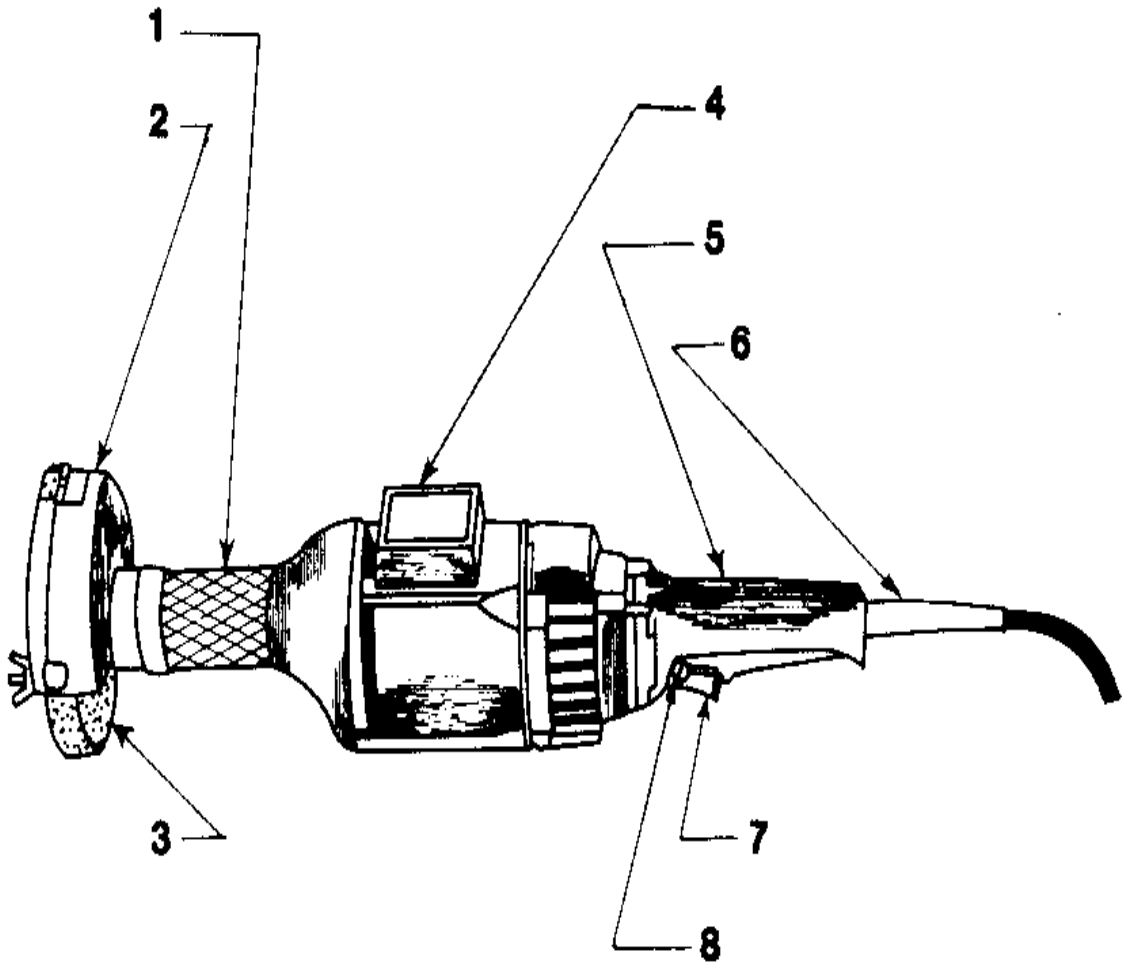

BASIC PORTABLE GRINDER PARTS

