

Radial Arm Saw

I. Competencies

Given a properly adjusted radial arm saw, instruction and demonstration of use, each student will be able to:

- A. Identify the major parts of the radial arm saw.
- B. Pass a written test on safety and operating procedures of the radial arm saw with 100% accuracy.
- C. Demonstrate the ability to safely crosscut, bevel, miter and dado with the radial arm saw while following all safety rules and correct operating procedures.

Note: The preparers of these safety materials do not recommend the use of the radial arm saw for ripping purposes; Use of the table saw is safer.

II. Instructional Materials and Procedures

A. Identification of Basic Radial Arm Saw Parts

- | | | | |
|-------------------|----------------|----------------------|--------------------------|
| 1. Double Overarm | 6. Fence | 10. Miter Latch | 14. Anti-Kickback Device |
| 2. Overarm Lock | 7. Miter Scale | 11. Yoke | 15. Table |
| 3. Swivel Latch | 8. Switch | 12. Handle | 16. Elevating Handwheel |
| 4. Column | 9. Track Arm | 13. Bevel Index Knob | |
| 5. Blade Guard | | | |

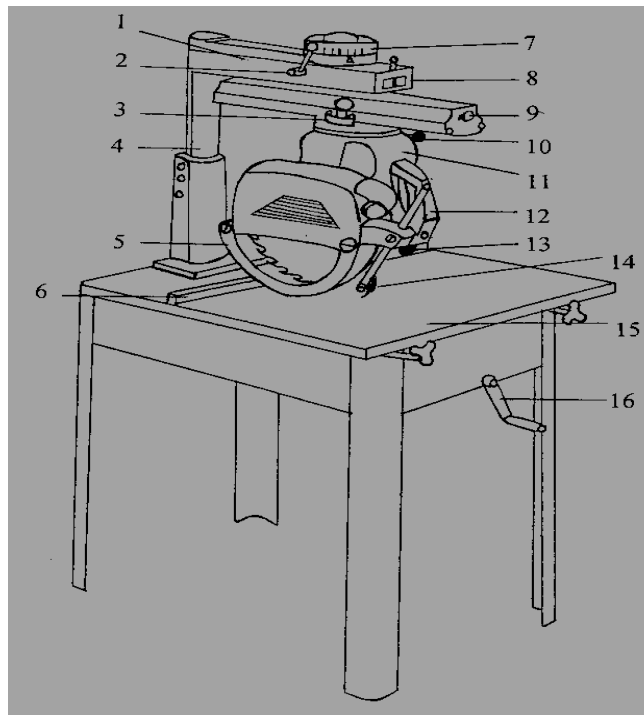

B. Radial Arm Saw Safety

1. Remove or fasten loose articles of clothing such as long sleeves, coats, neck ties and confine long hair.
2. Do not wear gloves.
3. Remove jewelry such as finger rings and bracelets.
4. Wear industrial quality eye protection and ear protectors.
5. Keep the work space around the saw free from scraps, sawdust, and oil or grease. The use of anti-skid strips is recommended for the floor area where the operator stands.
6. When setting up to work, check the saw blade for missing teeth and cracks. Make sure the blade is properly mounted. Keep the saw blade clean and sharp.
7. Do not operate the saw without permission from the instructor.
8. Be certain that hand tools and loose stock are removed from the saw table before using.
9. Always turn the power off and wait until the blade stops rotating before removing wood scraps or leaving the radial arm saw.
10. Disconnect the electrical service at the source before changing blades.
11. Guards should be in place and used at all times.
12. Devote your undivided attention to the work being performed. Do not talk to others or be engaged in "horseplay" while using the radial arm saw.
13. Avoid awkward work positions, they could result in slips which may cause contact with the saw blade. Establish a comfortable position prior to sawing.
14. Check the stock for nails, screws, and loose knots before sawing.
15. Always pull the saw through the stock slowly to insure full control. This saw tends to pull itself into the work and it may have to be held back on thick stock.

16. After the cut is complete, return the saw to the rear of the table before removing stock. The radial arm saw should have a safety return spring device which automatically returns the saw to the rear of the table.
17. Be sure material is held firmly against the guide fence and table before starting a cut. Support long pieces of stock.
18. Keep the blade and arbor flanges free from dirt and grease.
19. Be sure all clamps and locking handles are properly tightened before operating the radial arm saw.
20. Lock the saw yolk in position to prevent it from moving forward when the power is turned on.
21. Allow the saw to reach full speed before starting a cut.
22. Always stand with your face and body to one side of the saw blade.
23. Do not saw stock shorter than 12 inches
24. After the power is cut off, do not stop the blade by allowing it to cut into a board.

C. Radial Arm Saw Basic Operating Procedures

1. Changing the saw blade
 - a. Shut off main power switch or disconnect from wall plug.
 - b. Select the proper type blade for the job.
 - c. Remove the saw guard, arbor nut and arbor collars. Remove the blade.
 - d. Replace inside arbor collar with recessed face toward the blade.
 - e. Place the saw blade on the arbor so the teeth point in the direction of rotation.
 - f. Replace arbor collar and tighten the arbor nut.
 - g. Before replacing the guard, check the squareness of the saw blade. If out of adjustment, consult the operator's manual for alignment procedures.

- h. Rotate the saw blade by hand to see that it turns clear and free and does not cut into the table when pulled forward.
- i. Replace the blade guards and lock the saw in place.

2. Crosscutting

- a. Select a crosscut or combination blade.
- b. Be sure blade guards are in place.
- c. Adjust the depth of cut by turning the elevating handwheel. The teeth of the blade should be 1/16" below the surface of the stock.
- d. Push the saw to the rear of the table; tighten the lock to keep the saw from running forward when it is turned on.
- e. Adjust the saw blade to form a right angle with the fence and perpendicular to the table.
- f. Place material to be cut on the saw table with the straightest edge against the fence. Align the cutoff mark with the saw blade.
- g. Be sure the saw blade is not engaging the material, then start the saw and release the lock.
- h. Always pull the saw by the yolk handle. Do not cross your arms to pull the saw. If you hold the material on the right of the saw blade, pull the yolk with the left hand. Most accidents happen when the arms are crossed.
- i. Pull saw slowly toward the operator; keep the arm stiff to prevent the saw from grabbing and lunging forward.
- j. Return the saw to the rear of the table (some radial saws will do this automatically). Tighten the saw lock and turn the switch off.
- k. Apply blade brake slowly if one is available on your machine.

3. Miter Cutting

- a. Select a crosscut or combination blade.
- b. Set the angle of the miter cut.
- c. Make the cut in the same manner as described for crosscutting.

4. Bevel Cutting

- a. Select a quality crosscut or combination blade.
- b. Lock the overarm and yoke in the same position as for crosscutting.
- c. Raise the saw using the elevating handle until the motor can be tilted to the desired bevel. Release the bevel latch and bevel clamp handle.
- d. Tilt the saw to the desired bevel as indicated on the bevel scale.
- e. Re-engage the bevel latch and tighten the bevel clamp.
- f. Make the cut in the same manner as described for crosscutting.
- g. A compound angle cut is a combination bevel and miter cut.

5. Dadoing

- a. Select and install a dado head of desired width.
- b. Set the overarm and the motor yoke in the same position as for crosscutting.
- c. Place the lumber on the table, and lower the dado head until the teeth just touch the top of the board to be dadoed.
- d. Push the saw to the rear of the table, and lower the dado head to the desired depth of cut.
- e. Make the cut in the same manner as described for crosscutting.

III. Safety Test

Radial Arm Saw Safety and Operation Test

NAME _____ DATE _____ CLASS _____

Multiple Choice – Place the letter of the most correct answer on the answer sheet.

1. When sawing with the radial arm saw, which of the following should not be done?
 - a. Use the blade guard
 - b. Wear protective eye covering
 - c. Stand in line with the saw blade
 - d. Secure a helper or use a support for long stock

2. When making a crosscut with the radial arm saw, the blade should extend below the surface of the stock approximately _____.
 - a. 1/16"
 - b. 1/8"
 - c. 1/4"
 - d. 3/8"

3. Which type blade may be used for a crosscut on a radial arm saw?
 - a. Crosscut
 - b. Ripping
 - c. Combination
 - d. Both a and c
 - e. Both b and c

4. Do not saw stock with a length less than _____.
 - a. 8"
 - b. 10"
 - c. 12"
 - d. 14"

5. The depth of cut is adjusted by turning the _____.
 - a. elevating handwheel
 - b. locating pin
 - c. motor yoke
 - d. saw yoke

6. Which of the following cuts is a combination bevel and miter cut?
- Compound
 - Simple
 - Dado
 - Bevel
7. After a cut has been made, the following should be completed before leaving the radial arm saw _____.
- return the saw to rear of table
 - remove wood scraps
 - wait until the blade stops rotating
 - all of these are correct
8. When the saw is perpendicular to the table the bevel scale should read _____.
- 0 degrees
 - 60 degrees
 - 90 degrees
 - none of these
9. Before making a cut with the radial arm saw you should _____.
- allow the saw to reach full speed
 - hold the saw to prevent it from coming forward
 - make sure all locking handles are secure
 - all of the above
10. When performing a crosscut with the radial arm saw _____.
- place the material to be cut against fence
 - adjust saw at correct angle to fence
 - adjust the height of the blade
 - all of the above
11. Which of the following should be completed before using the radial arm saw?
- Support long end of stock
 - Adjust depth of cut
 - Check stock for nails, knots
 - All of the above

12. The radial arm saw should be held firmly to regulate the rate of cut, since the saw _____.
- vibrates
 - feeds itself into the work
 - cuts too deep
 - none of the above
13. The radial arm saw should be operated only after _____.
- obtaining the instructor's permission
 - wearing approved eye protection
 - removing jewelry
 - all of the above
14. When crosscutting on the radial arm saw with most of the stock to the right of the blade _____.
- hold the long portion of the stock with the right hand and pull the saw with the left hand
 - hold the long portion of the stock with the left hand and pull the saw with the right hand
 - hold the short portion of stock with the right hand and pull the saw with the left hand.
 - hold the short portion of stock with the left hand and pull the saw with the right hand
15. Which statement is false regarding crosscutting on the radial arm saw?
- The teeth of the saw should cut about 1/16 inch below the surface of the stock
 - The saw blade rotates down into the stock and helps hold it against the fence
 - Because of the blade rotation the saw takes some effort to pull it across the stock
 - Stock should never be cut while pushing the saw to the rear of the table
16. Establish a comfortable, stable position for sawing _____.
- by sawing a few scraps
 - before starting to saw
 - by moving around while sawing
 - by the trial and error method

Radial Arm Saw Parts Identification Test

Name _____

Match the number of each radial arm saw part with the letter of the correct part name.

- | | |
|-----------------------------|------------------------------|
| ___ 1. Overarm Lock | ___ 9. Elevating Handwheel |
| ___ 2. Switch | ___ 10. Fence |
| ___ 3. Swivel Latch | ___ 11. Handle |
| ___ 4. Table | ___ 12. Column |
| ___ 5. Track Arm Index Knob | ___ 13. Miter Latch |
| ___ 6. Bevel Index Knob | ___ 14. Miter Scale |
| ___ 7. Yoke | ___ 15. Anti-Kickback Device |
| ___ 8. Double Overarm | ___ 16. Blade Guard |

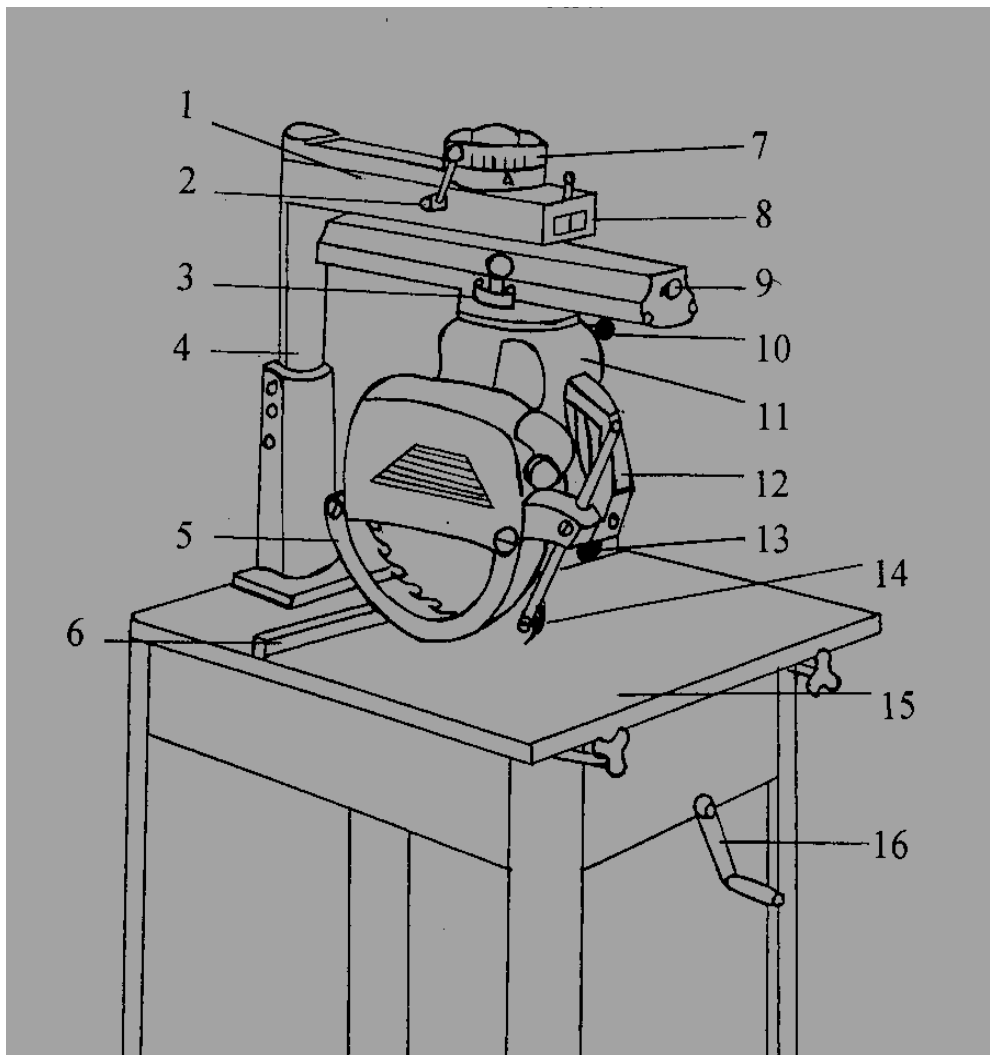

Radial Arm Saw

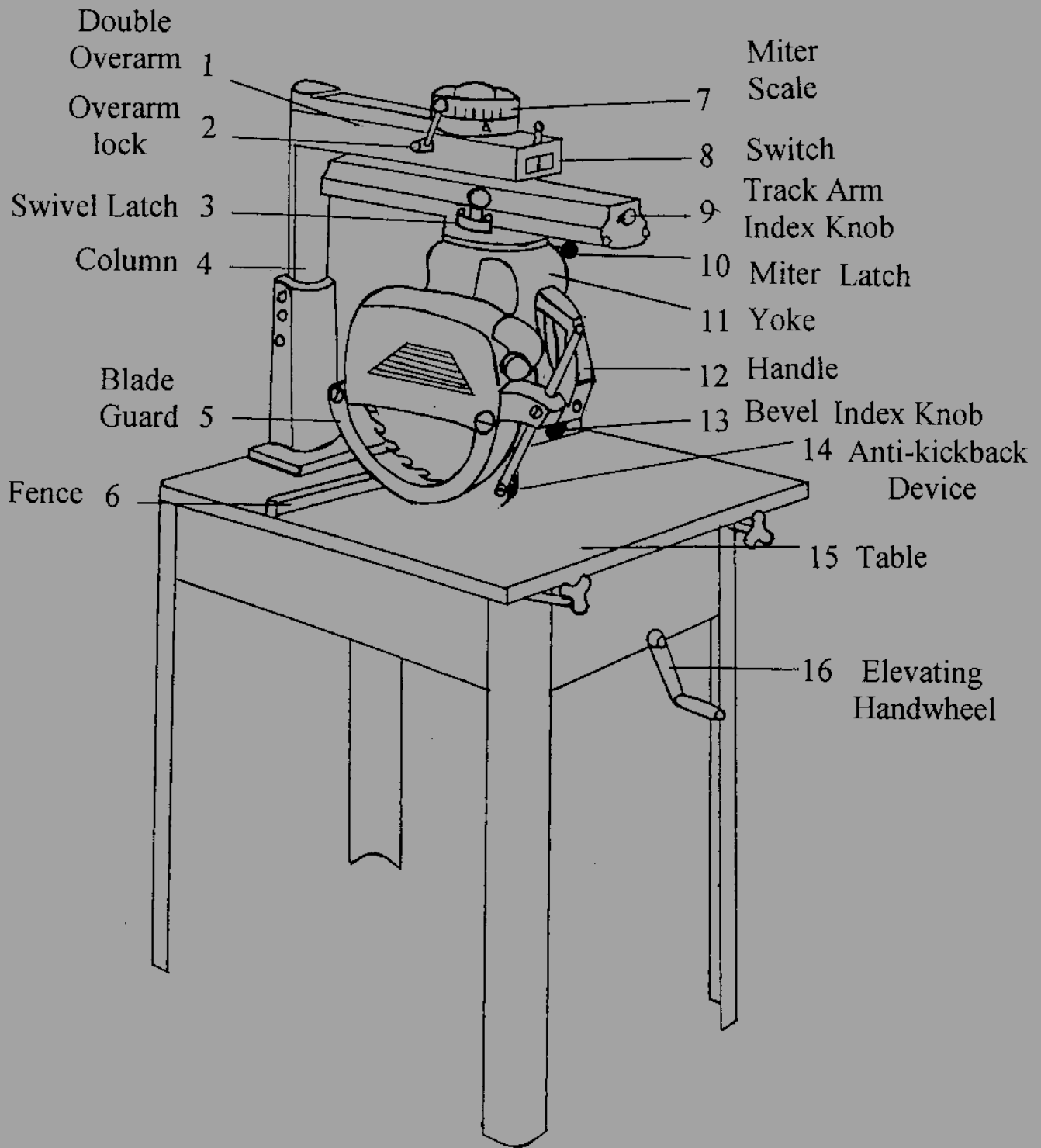

Radial Arm Saw

